

Regenerative Electric Power Treatment of Servo Motor Using a Chopper and Electrolytic Capacitor

Yuji Ide

Keigo Kikuchi

Masahisa Koyama

1. Introduction

Energy conservation has become a critical issue in recent years for the purpose of preserving the earth's environment. One of the methods of saving energy is motor power regenerative electric power through the power supply, but this involves complicated control and also higher cost. Another widely known method is regeneration through resistance, which is simple to control and cheap, but has no means of saving energy and suffers a large heat dissipation. A further regeneration method is to simply increase the capacity of the smoothing capacitor of the motor control device. However, this method requires an extremely large capacity smoothing capacitor, and also requires a rush current prevention circuit and increased capacitance in the discharging circuit.

This report proposes a new method of handling regenerative electric power, in which a separate electrolytic capacitor is used in addition to the smoothing capacitor, the charging and discharging of which are controlled by a power converter. We have confirmed satisfactory operation through our experiments and obtained good results as reported here.

2. Regenerative Electric Power to a Capacitor

The amount of regenerative electric power when the rotation speed of a motor decelerates from ω to 0 is given by the following equation.

$$P_b = 1/2 \cdot J \cdot \omega^2 - P_m \quad \text{---(1)}$$

where, J : Inertia

P_m : Amount of internal power consumption in the motor

The amount of electric power that is stored in an electrolytic capacitor having static capacitance C is given by the following equation, when the voltage increases from V_1 to V_2 .

$$P_c = 1/2 \cdot C \cdot (V_2^2 - V_1^2) \quad \text{---(2)}$$

When the regenerative electric power of a motor is stored in an electrolytic capacitor through a power converter, using equations (1) and (2) and letting the efficiency of the power converter be η , the capacitance of the electrolytic capacitor is given by equation (3).

$$C = (J \cdot \omega^2 - 2 \cdot P_m) \cdot \eta / (V_2^2 - V_1^2) \quad \text{---(3)}$$

This equation shows that the higher the V_2 voltage is, the smaller the capacitance of

the electrolytic capacitor required to store the regenerative electric power. About 800 V is the practical upper limit of voltage V_2 due to the limited withstand voltage of the electrolytic capacitor and semiconductors.

In practice, the regenerative electric power becomes a sawtooth wave as shown in [Fig. 1](#) when a motor is decelerated at a constant torque. Thus, the rise-up of the regenerative electric power is sharp when the motor starts to decelerate. An electrolytic capacitor must have already been charged in order to absorb this regenerative electric power. Since electric power can be expressed by the product of voltage and current, the regenerative electric power cannot be absorbed unless an infinite current flows when voltage = 0. In other words, $V_1 > 0$. We have charged an electrolytic capacitor to the same voltage as that of the motor control device in order to simplify the circuit configuration.

Here, we compare the required capacitance of the capacitor in our method with that of the regenerative method in which the capacitance of the smoothing capacitor is simply increased. For the purpose of comparison, $V_2 = 395$ V is used in the regenerative method in which the capacitance of the smoothing capacitor is simply increased. $V_2 = 800$ V is used in our system while all other items are kept the same between the two systems. The required capacitance of the capacitor can be calculated from equation (3) assuming that the power supply voltage is AC 253 V ($V_1 = 358$ V). Equation (3) shows that the required capacitance of a capacitor in our system is 5.4%, which is required in the method in which the capacitance of the smoothing capacitor is simply increased. Therefore, a capacitor having a reasonably small capacitance can handle the regenerative electric power in our system. The internal power consumption in a motor is expressed by equation (4)

$$P_m = W_m \cdot t_b \quad \text{---(4)}$$

where, W_m : Motor loss, t_b : Deceleration time

The deceleration time can be calculated using equation (5)

$$t_b = J \cdot \omega / T_b \quad \text{---(5)}$$

where, T_b : Deceleration torque

3. Circuit Configuration

The circuit configuration of the regenerative electric power processing device that is connected to the servo motor control system is shown in [Fig. 2](#). The power converter of the voltage step-up/down converter consisting of a DC reactance and IGBT is used which controls the charging and discharging of the electrolytic capacitor connected to the output circuit. The DC voltage command V_{DC}^* is set slightly higher than the output voltage of the AC power full-wave rectification voltage so that the current command I_{DC}^* is output such that the DC voltage V_{DC} is constant during charging and discharging of the electrolytic capacitor. The DC current I_{DC} is controlled by the P controller. A differential compensator D is added to improve the response characteristics for the sharp rise-up of the regenerative electric power. Overshoot of the DC voltage must be adequately suppressed due to the limited withstand voltage of the motor control system. Capacitance C_2 of the smoothing capacitor of the motor control system can affect the characteristics of the entire system, but its effect is minimized by applying a sufficiently large differential compensation compared with C_2 .

When the main power is turned on, the electrolytic capacitor C_1 is charged to the

same voltage as the motor control system through a diode of the chopper. When the regenerative voltage is returned from the motor, the DC voltage increases so that the charging current flows to charge the electrolytic capacitor C1 that stores the electric charge as the regenerative electric power. When motor receives power and enters the power running state, the DC voltage decreases so that the discharging current flows to discharge the electrolytic capacitor C1 and the stored electric charge is used to power the motor. Thus the electrolytic capacitor repeatedly charges and discharges whenever the motor repeats regeneration and power running. The regenerative electric power of the motor is thus effectively used, and so the input power to the motor from the power supply becomes smaller.

4. Result of Experiments

Experiments were conducted using an induction motor having a maximum output of 15 kW under the measurement conditions shown in Table 1. The operating characteristics of the motor are shown in Fig. 3 when the motor is decelerated 157 rad/s to 0 at a constant torque and then accelerated back again. The voltage across the electrolytic capacitor increases to the maximum of 700 V during deceleration. The voltage across the electrolytic capacitor starts discharging when the rotating speed of the motor is 0 due to excitation current loss of the motor. During power running of the motor, the voltage across the electrolytic capacitor is discharged close to the voltage VDC. The voltage VDC characteristics are such that there is no over-shoot due to differential compensation, so the electrolytic capacitor can be charged and discharged while keeping VDC at a constant voltage. When discharge of an electrolytic capacitor is completed, the voltage VDC has decreased to the output voltage of the AC power full-wave rectifier since electric power starts to be supplied from the AC power source.

From heat tests at the rated output of 2.2 kW with the maximum output of 15 kW, the estimated life of the electrolytic capacitor is 20 years or more, thus the system is feasible.

Fig. 4 shows the relation between the rotating speed of the motor and the capacity of the electrolytic capacitor when the capacity is changed under the measuring conditions of Table 1 and under the maximum voltage of 700 V across the capacitor. The experiment was conducted while the deceleration torque was kept constant at 86 Nm. The actual measured value agrees sufficiently closely with the theoretical value. The capacity of an electrolytic capacitor is proportional to the second power of the rotating speed of a motor. The regenerative electric power is not returned from the motor when the rotating speed is 30 rad/s or less, indicating that an electrolytic capacitor is not necessary.

The charging and discharging efficiency of this system is 80%.

Table 1 Measurement conditions

Inertia 0.25Kg·m ²	Power supply voltage AC200V
VDC* 300V	PWM frequency 15KHz
Reactor 1mH	Electrolytic capacitor 8150#F

5. Conclusion

This report proposes a new method of regenerative electric power, in which

charging/discharging are controlled using a power converter. We have confirmed experimentally that the system operates satisfactorily. This system has the following features:

- Energy saving

(80% of the regenerative electric power that has been dissipated in the conventional regenerative system using a resistor, can be effectively used.)

- Low heat dissipation

- Simple control
- Low cost
- Regenerative treatment of power is possible with a small capacity electrolytic capacitor

- Amount of regenerative electric power at one time is limited.

(i.e., the motor must operate power-running after power is regenerated)

(i.e., continuous regeneration of power is not possible)

These features make the system suitable for the feed shaft of a servo system that is accelerated and decelerated very frequently.

References

(1) Ide, Kikuchi, Koyama:"Regenerative Electric Power Treatment System Using an Electrolytic Capacitor" 1997 National Convention IEE Japan, 974 (1997-3)

(2) Izumi, Nakaoka, Kimura:"A Consideration on Optimal Control of a Servo System Regenerating Conservative Energy to a Condenser" Transaction D, IEE Japan, Vol.115, No.6, pp.816-817 (1995-6)

Yuji Ide

Joined company in 1984

Servo Systems Division, Servo Engineering Dept.

Worked on research and development of motor controlling system

Keigo Kikuchi

Joined company in 1985

Servo Systems Division, Servo Engineering Dept.

Worked on research and development of motor controlling system

Masahisa Koyama

Joined company in 1990

Servo Systems Division, Servo Engineering Dept.

Worked on research and development of motor controlling system

Fig. 1 Example of regenerative electric power when motor is decelerated at a constant torque

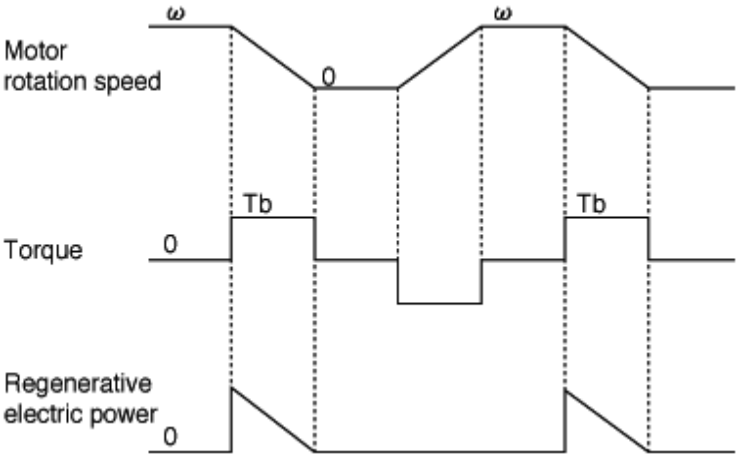

Fig. 2 Circuit configuration

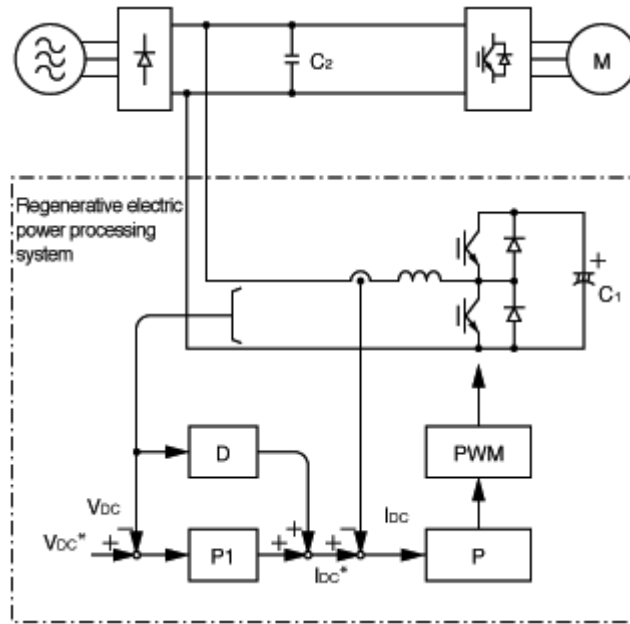

Fig. 3 Motor operating characteristics during deceleration and acceleration

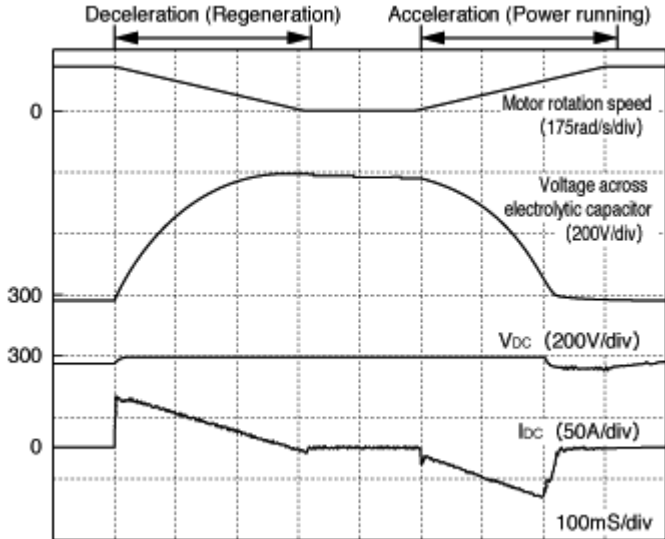

Fig. 4 Relation between rotating speed of motor and capacity of electrolytic capacitor

